



Certified to
NSF/ANSI 61 & 372

RPV Series Pressure Relief Valves

1/4" TO 4" / DN8 TO DN100
PVC, CPVC, PP AND PVDF

KEY FEATURES

- Available in PVC, CPVC, PP or PVDF Body with Noryl™ Molded Dome
- PTFE/EPDM Diaphragm
- Spring: 10 – 150 psi (Spring pre-set: 50 psi)
- 304 Stainless Steel Bolting
- FNPT Threads
- Adjustment Screw with Slot
- PVC, CPVC and PVDF rated to 250 psi @ 70°F / 17.2 Bar at 21°C, PP rated to 150 psi @ 70°F / 10 Bar at 21°C

OPTIONS

- 2-port / 90°
- ANSI or DIN / EN Threaded, Socket, True Union Socket or Flanged End Connections
- 0 - 50 psi and 10 - 250 psi Springs
- PTFE/FPM Diaphragm

MATERIALS

- PVC Cell Class 12454 per ASTM D1784
- CPVC Cell Class 23447 per ASTM D1784
- PP per ASTM D4101
- Natural PVDF per ASTM D3222 Type 1

TECHNICAL INFORMATION

DETAILED VIEW

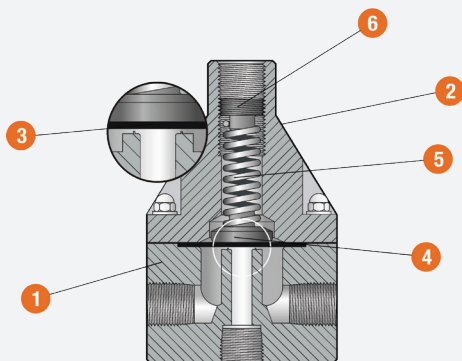

SELECTION CHART

SIZE	MATERIAL	END CONNECTION	DIAPHRAGM	PRESSURE ADJUSTMENT	PRESSURE RATING
1/4"-3/8" DN8-DN10	PVC, CPVC, PP, PVDF	FNPT	PTFE/EPDM, PTFE/FPM	10-150 psi Optional: 0-50, 10-250	375 PSI @ 70°F 25 Bar @ 21°C Non-Shock
1/2"-2" DN15-DN50	PVC, CPVC, PP, PVDF	FNPT, Socket, Flange			
1/2"-2" DN15-DN50	PVC, CPVC	TU Socket			
3"-4" DN80-DN100	PVC, CPVC	Flange			

RPV Series Pressure Relief Valves

1/4" TO 4" PVC, CPVC, PP OR PVDF

TECHNICAL INFORMATION, CONTINUED

PARTS LIST

1. Valve Body - PVC, CPVC, PP or PVDF
2. Dome - Noryl™
3. Diaphragm - PTFE/EPDM or PTFE/FPM
4. Compressor
5. Spring
6. Adjustment Screw

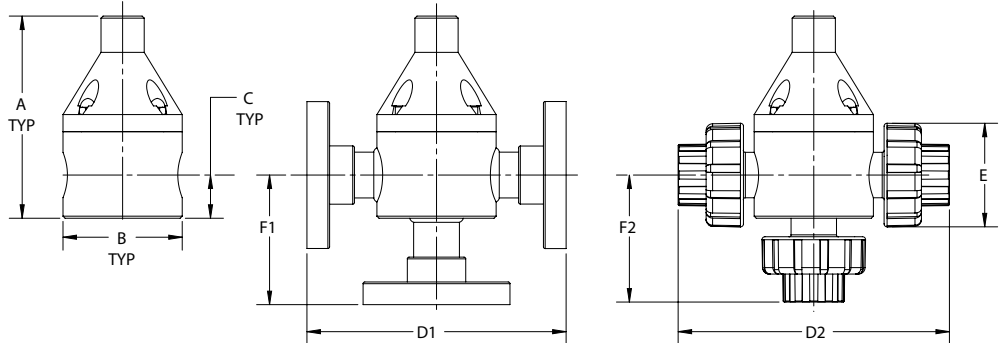

DIMENSIONS (INCHES / MILLIMETERS)

VALVE SIZE in / DN	A in / mm	B in / mm	C in / mm	D1 ¹ in / mm	D2 ¹ in / mm	E in / mm	F1 ¹ in / mm	F2 ¹ in / mm
1/4 / 8	3.55 / 90	2.35 / 60	0.75 / 19	-	-	-	-	-
3/8 / 10	3.55 / 90	2.35 / 60	0.75 / 19	-	-	-	-	-
1/2 / 15	4.25 / 108	2.35 / 60	1.08 / 27	7.50 / 191	6.90 / 175	2.25 / 57	3.75 / 95	2.90 / 74
3/4 / 20	5.56 / 141	3.50 / 89	1.13 / 29	7.50 / 191	7.30 / 185	2.62 / 67	3.75 / 95	3.15 / 80
1 / 25	5.86 / 149	3.50 / 89	1.25 / 32	7.50 / 191	7.85 / 199	3.00 / 76	3.75 / 95	3.68 / 93
1-1/2 / 40	8.35 / 212	4.90 / 124	1.83 / 47	10.50 / 267	14.30 / 363	4.00 / 102	-	-
2 / 50	8.90 / 226	4.90 / 124	2.15 / 55	10.50 / 267	11.0 / 279	4.75 / 121	-	-
3 / 80	11.75 / 298	5.95 / 151	3.0 / 76	15.0 / 381	-	-	-	-
4 / 100	11.75 / 298	5.95 / 151	3.0 / 76	17.0 / 432*	-	-	-	-

*PP & PVDF: 15.0 / 381

¹End to End dimensions will vary on flanged and true union styles due to some solvent cement construction.

PERFORMANCE CURVE

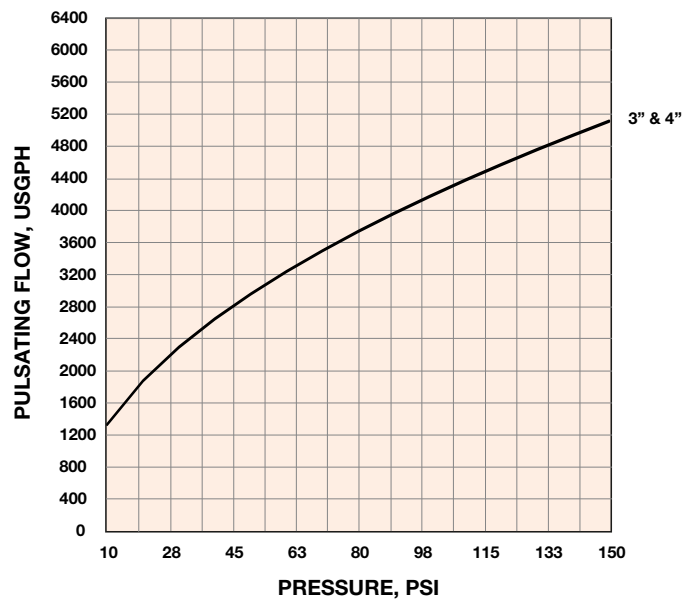
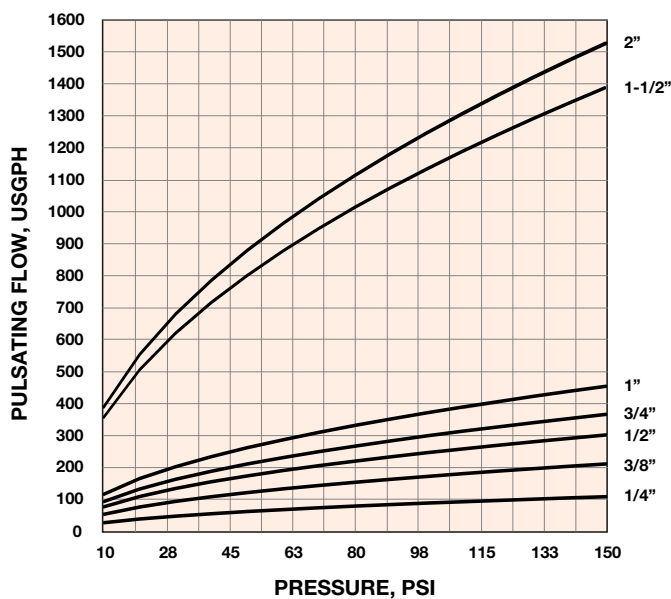

Hayward is a registered trademark of Hayward Industries, Inc. © 2022 Hayward Industries, Inc.

USA: 1.888.429.4635 • Fax: 1.888.778.8410 • One Hayward Industrial Drive • Clemmons, NC 27012 • Email: hfcsales@hayward.com
 Canada: 1.888.238.7665 • Fax: 1.905.829.3636 • 2880 Plymouth Drive • Oakville, ON L6H 5R4 • Email: hflowcanada@hayward.com
 Visit us at: haywardflowcontrol.com