



SW Series Swing Check Valves

3" TO 6" PVC, CPVC AND GFPP
AND 8" PVC AND GFPP

KEY FEATURES

- Available in PVC, CPVC and GFPP
- High Temperature/Pressure Ratings
- Horizontal or Vertical Installation
- Two-in-One Seat Design
- Built-in Flange Seals
- Two Drain Ports
- Self-Aligning Clapper Seals
- High Cv Rating and Full Flow Design

OPTIONS

- Counterweight for Closing Assistance
- Limit Switch for Position Indication

MATERIALS

- PVC Cell Class 12454 per ASTM D1784
- CPVC Cell Class 23447 per ASTM D1784
- GFPP Cell Class 85580 per ASTM D4101
- FPM and EPDM O-Ring Seals

TECHNICAL INFORMATION

EXPLODED VIEW

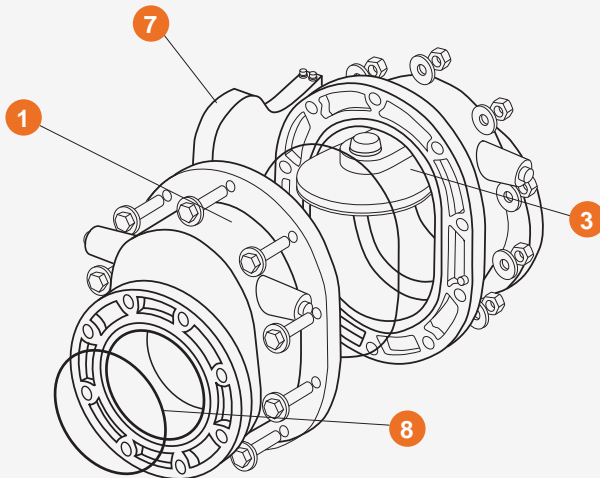

SELECTION CHART

SIZE	MATERIAL	END CONNECTION	SEALS	PRESSURE RATING
3" – 6" (DN80 – DN150)	PVC, CPVC or GFPP	Flanged	FPM or EPDM	150 PSI @ 70°F 10 Bar @ 21°C Non-Shock
8" (DN200)	PVC or GFPP			

* Flanged ends available in DIN / EN PN10.

SW Series Swing Check Valves

3" TO 6" PVC, CPVC AND GFPP AND 8" PVC AND GFPP

TECHNICAL INFORMATION, CONTINUED

PARTS LIST

1. Body
2. Swing Arm
3. Clapper
4. Shaft*
5. Body Seal
6. Drain Plug (2)
7. Counter Weight (Optional)
8. O-Ring Face Seal

* PVC with PVC valves
PVDF with GFPP Valves
CPVC with CPVC valves

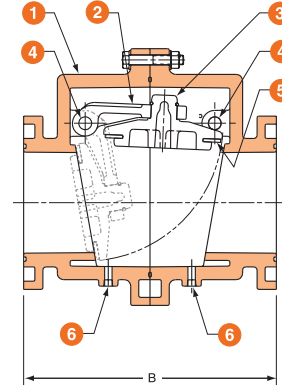
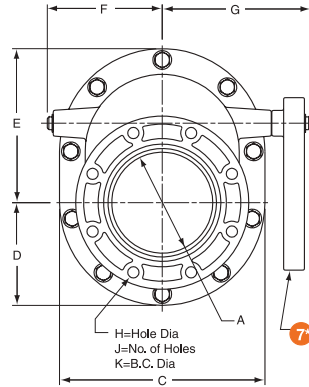

DIMENSIONS

SIZE in / DN	A in / mm	B in / mm	C in / mm	D in / mm	E in / mm	F in / mm	G in / mm	H in / mm	J in / mm	K in / mm	MINIMUM BACK PRESSURE TO CLOSE - PSI	WEIGHT lbs / kg
3 / 80	3.00 / 76	10.24 / 260	7.50 / 191	3.75 / 95	5.21 / 132	3.90 / 99	4.91 / 125	.62 / 16	4.00 / 102	6.00 / 152	3	10.00 / 4.54
4 / 100	3.90 / 99	11.81 / 300	9.25 / 235	4.63 / 118	6.75 / 171	4.80 / 122	6.15 / 156	.62 / 16	8.00 / 203	7.50 / 191	3	21.00 / 9.53
6 / 150	5.91 / 150	15.75 / 400	12.75 / 324	6.38 / 162	9.25 / 235	6.47 / 164	8.30 / 211	.75 / 19	8.00 / 203	9.50 / 241	3	47.00 / 21.32
8 / 200	7.87 / 200	19.69 / 500	16.00 / 406	8.00 / 203	12.00 / 305	8.96 / 228	11.54 / 293	.75 / 19	8.00 / 203	11.75 / 298	3	90.00 / 40.82

Dimensions are subject to change without notice – consult factory for installation information

Cv VALUES

SIZE in / DN	Cv VALUES	SIZE in / DN	Cv VALUES
3 / 80	328	6 / 150	1,278
4 / 100	514	8 / 250	2,549

PRESSURE LOSS CALCULATION FORMULA

$$\Delta P = \left[\frac{Q}{Cv} \right]^2$$

ΔP = Pressure Drop

Q = Flow in GPM

Cv = Flow Coefficient

OPERATING TEMPERATURE/PRESSURE

3" TO 8" SWING CHECK VALVE

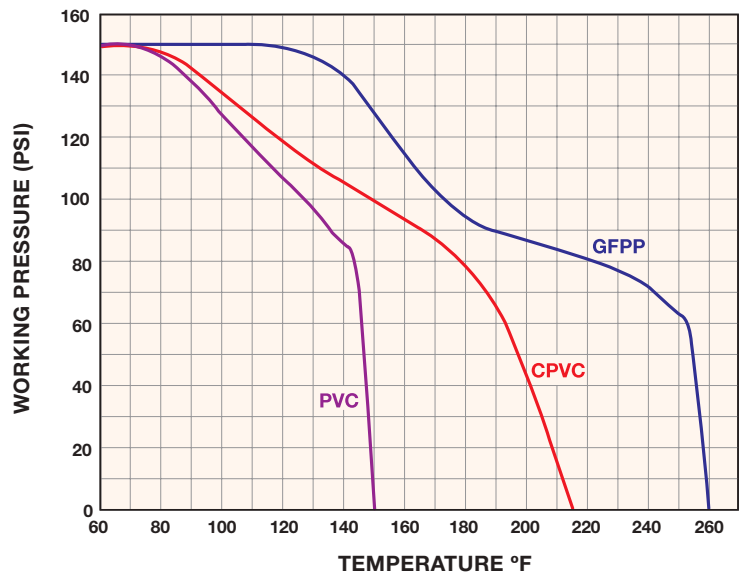

Hayward is a registered trademark
of Hayward Industries, Inc.
© 2021 Hayward Industries, Inc.

USA: 1.888.429.4635 • Fax: 1.888.778.8410 • One Hayward Industrial Drive • Clemmons, NC 27012 • Email: hfcsales@hayward.com

Canada: 1.888.238.7665 • Fax: 1.905.829.3636 • 2880 Plymouth Drive • Oakville, ON L6H 5R4 • Email: hfcanada@hayward.com

Visit us at: haywardflowcontrol.com