

Lug Style Butterfly Valve Type 578



General

- **Size:** 2"–12"
- **Outer Body:** Glass-filled PP
- **Material:** PVC, CPVC, PROGEF® Standard PP, ABS, SYGEF® Standard PVDF
- **Seals:** EPDM, FPM, PTFE/FPM
- **Stem:** 316 Stainless steel
- **Lugs:** 316 Stainless steel
- **Connection:** ANSI 150
- **Operation:** Bare shaft, lever, gear

Key Certifications

- **NSF 61:** PVC and CPVC
- **FDA CFR 21 177.1520:** PP and PVDF
- **FDA CFR 21 177.2600:** EPDM and FPM
- **FDA CFR 21 177.1550:** PTFE
- **USP 25 Class VI (physiological non-toxic):** PP and PVDF

Sample Specification

The Type 578 Butterfly Valve shall be lug style compatible with ANSI B16.5 150 lb flange pattern. The operation shall utilize double eccentric design principles. The shaft shall be non-wetted by a bushing assembly with double o-ring seals. The face seal shall be a Q-ring compatible with flat and serrated flange adapters. The face, disk and shaft seals shall operate independently. The wetted body and disk shall be of like materials. The outer body shall be glass-filled polypropylene with over-molded 316 stainless steel lug inserts. Valves shall be rated for bidirectional use. All valves shall be tested in accordance to ISO9393 and designed to ISO16136 standards. All valves shall be manufactured under ISO9001 for Quality and ISO14001 for Environmental Management. Following assembly, every valve shall be tested and certified bubble tight exceeding Class VI standards.

Material Specification

PVC valves shall meet ASTM D1784 cell classification 12454 standards. CPVC valves shall meet ASTM D1784 cell classification 23447-B standards. PP valves shall meet ASTM D5847-14 cell classification PP0510B66851 standards. ABS valves shall meet ASTM D3965 cell classification 42222 standards. PVDF valves shall be type 1, grade 2 according to ASTM D3222 standards. Valves of all materials shall be RoHS compliant.

Components

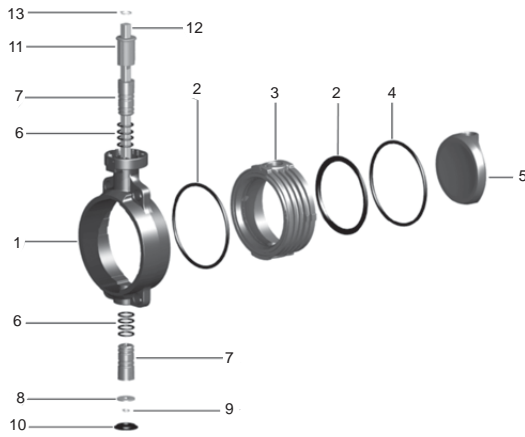

Material Availability

It is not possible to use inner housings with disks of different material. Valves of all sizes and materials are available with both EPDM and FPM seals. Only CPVC, PP and PVDF valves are available with PTFE encapsulated FPM disc seals. GF does not offer disc seals that deviate from their standard product offering.

Material	Range (inch)	Range (mm)
PVC	2-12	63-315
CPVC	2-12	63-315
PP	2-12	63-315
ABS	2-12	63-315
PVDF	2-12	63-315

Optional Features

- **Actuation:** Electric, pneumatic
- **Limit Switches:** Mechanical, inductive
- **Handle:** Find adjustment lever (1°), stem extension
- **Shaft:** Titanium, Hastelloy-C
- **Operation:** Chain operator, square operating nut
- **Gear Operator:** Stainless steel housing
- **Connection:** DIN 2501
- **Hardware:** Alternatives available upon request
- **Cleaned:** Silicone free/oil free

Valve Components

Part	Description	Material
1	Outer body (wafer shown)	Glass filled PP
2	Face seal	EPDM or FPM
3	Inner body	PVC, CPVC, PP, ABS or PVDF
4	Disk seal	EPDM, FPM or PTFE/FPM
5	Disk	PVC, CPVC, PP, ABS or PVDF
6	Shaft seal	EPDM or FPM
7	Shaft bushing	PVC, CPVC, PP, or PVDF
8	Washer	304 stainless steel
9	Lower retaining clip	304 stainless steel
10	Shaft cap	Glass filled PP
11	End stop	Glass filled PP
12	Shaft	316 stainless steel
13	Upper retaining clip	304 stainless steel



Key Design Features

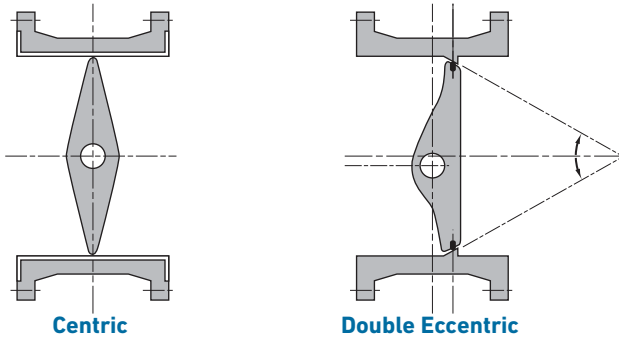

Seals

The Type 578 Butterfly Valve features a truly non-wetted shaft design. The shaft is sealed with a bushing assembly on either side of the disc. Each bushing utilizes a double o-ring seal totalling eight shaft seals in every valve.

Alternative o-ring shaft sealing designs are commonly found in competitive boot style thermoplastic butterfly valves. However, these solutions often rely upon elastomer on elastomer seals which can be unreliable, especially in chemical process applications or when working temperatures deviate from standard conditions. The Type 578 shaft seal design eliminates the need elastomer on elastomer seals, providing an industry tested dynamic double o-ring seal against a ridged thermoplastic surface.

The shaft, disc and face seals all operate independently from one another. This eliminates issues common to booted style centric valves such as crimping, where the compression of the valve between two flanges causes the boot to ripple. This can lead to increased operating torque and wear, ultimately reducing the useful life of the valve.



Double Eccentric Design Principle

The Type 578 Butterfly Valve is designed using the double eccentric disc principle. When opening and closing, the disc is not in contact with the seat, significantly reducing component wear. This design principle greatly reduces the operating torque and required elastomeric sealing material. The reduction in sealing material decreases the impact of elastomeric swelling. The benefits of double eccentric valves include ease of manual usage, reduction in required actuator torque and extended valve lifetime.



Lugs

The Type 578 Butterfly Valve lugs are overmolded SS316. They are keyed and notched to ensure they do not pull-out or rotate when in use.



PTFE Disc Seal

The Type 578 Butterfly Valve is available with a PTFE encapsulated FPM disc seal. The FPM core provides flexibility to the PTFE shell and allows for a reliable seal. The double eccentric design limits the amount of PTFE required. The face and shaft seals are FPM blended with approximately 15% PTFE.

Technical Data

Pressure-Temperature Curves

The following graphs are based on a lifetime of 25 years of water or similar media applications

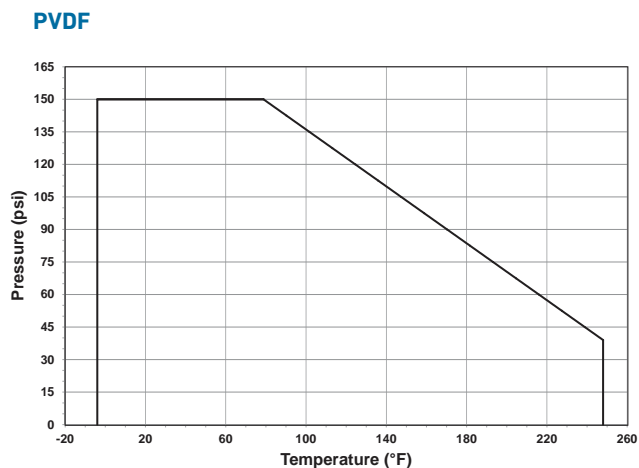
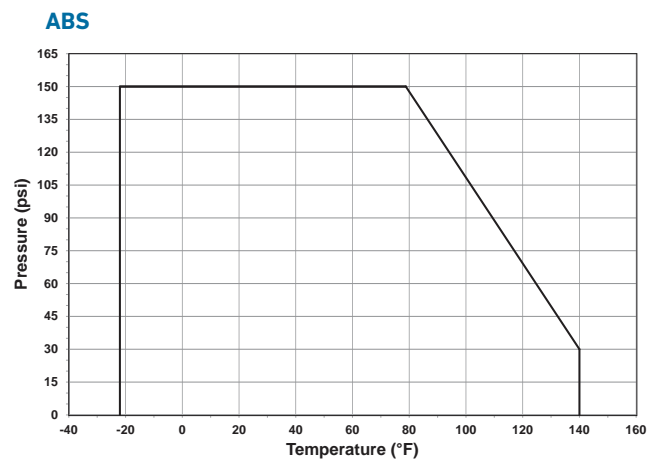
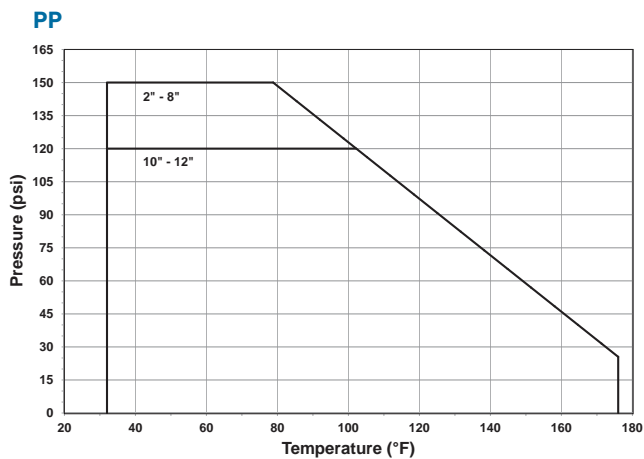
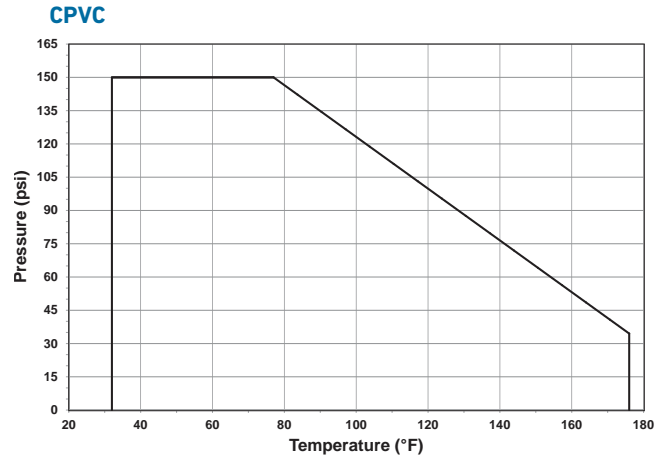
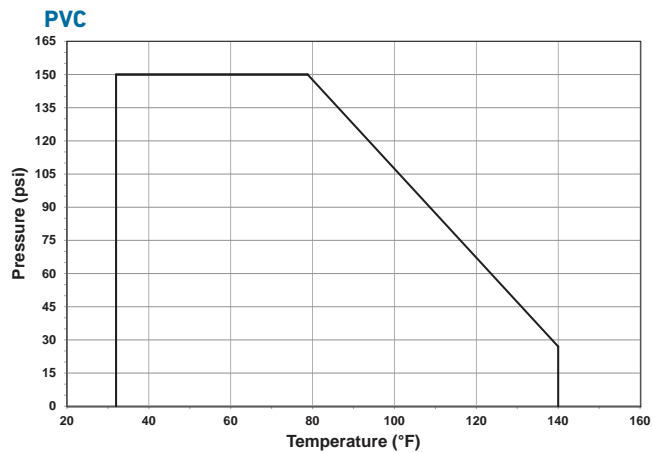

Pressure-Temperature

Material	Temperature Range (°F)	Max Pressure (psi)
PVC	32 to 140	150
CPVC	32 to 176	150
PP	32 to 176	150*
ABS	-40 to 140	150
PVDF	-4 to 284	150

*Dependant on size as shown in P-T curves

The Type 578 is rated for full vacuum service. Maximum differential pressure of 15psi at 122°F.

Flow

The following information is based on water applications at 68° F

Cv Value

Size (Inch)	d (mm)	Cv (gal/min)
2	63	103
2½	75	154
3	90	210
4	110	455
5	140	805
6	160	1162
8	225	2772
10	280	3570
12	315	5110

Flow Characteristics

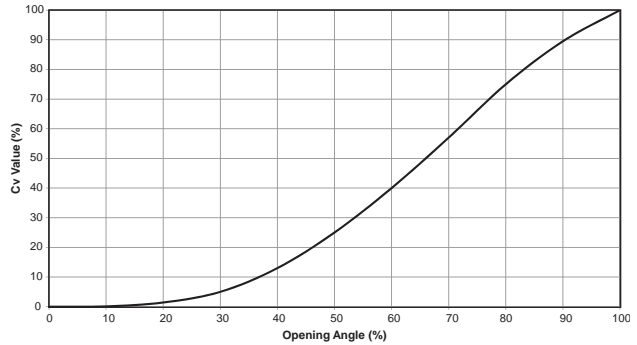

Breakaway Torque

The following tables show average values

Size (inch)	d (mm)	At 75psi Torque (ft-lb)	At 150psi Torque (ft-lb)
2	63	10	25
2½	75	10	30
3	90	20	45
4	110	30	60
5	140	40	75
6	160	50	90
8	225	75	120
10	280	100	170
12	315	130	220

For non-GF actuators, a safety factor should be used in calculating the required actuator torque. This safety factor can vary depending on the application conditions and end user's preference. (e.g. control time, medium, temperature, etc.).

Operator Components

Lever

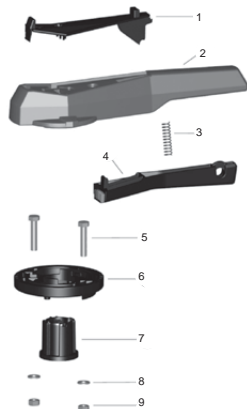

Lever Components

Part	Description	Material
1	Handle clip	Glass-filled PP
2	Handle	Glass-filled PP
3	Spring	304 Stainless steel
4	Lever	Glass-filled PP
5	Bolts	304 Stainless steel
6	Index plate	Glass-filled PP
7	Turn limiter	Glass-filled PP
8	Washers	304 Stainless steel
9	Nuts	304 Stainless steel

Gear Operator

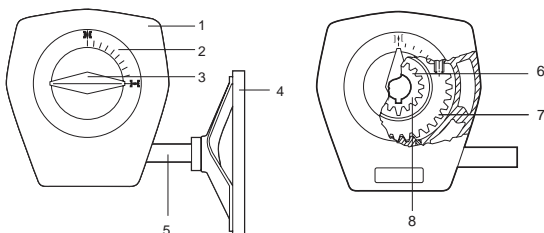

Gear Components

Part	Description	Material
1	Housing	Aluminum
2	Indicator cap	PE
3	Indicator	PE
4	Handle	Aluminum
5	Wormshaft	Nitempered steel
6	Drive bushing	Sintered copper steel
7	Quadrant	Sintered copper steel
8	Thrust bearing	Type AXK

Dimensions

The following tables are shown in millimeters unless otherwise specified

Bare Shaft

Size (inch)	D3	D4	H3	H4	H5
2	70	90	27	23	11
2½	70	90	27	23	11
3	70	90	27	23	11
4	70	90	16	23	14
5	70	90	16	23	14
6	70	90	19	23	17
8	70	90	19	23	17
10	102	125	40	23	22
12	102	125	40	23	22

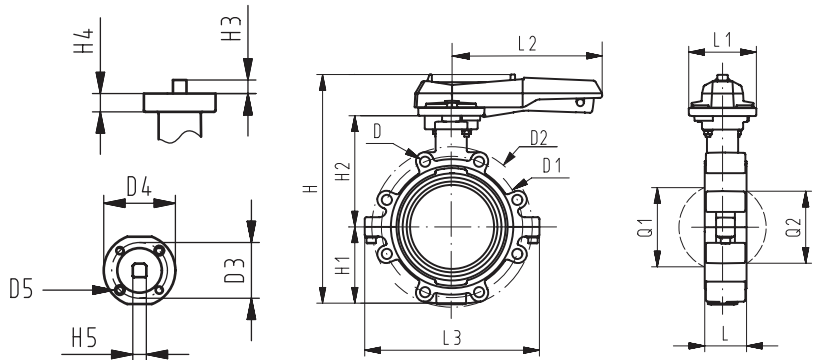

Lever

Size (inch)	D	D1	D2	H	H1	H2	L	L1	L2	L3	Q1	Q2
2	UNC 5/8	120.6	160	265	77	134	45	106	205	165	40	-
2½	UNC 5/8	139.7	180	277	83	140	46	106	205	182	54	35
3	UNC 5/8	152.4	195	289	89	146	49	106	205	210	67	50
4	UNC 5/8	190.5	226	328	106	167	56	106	255	240	88	74
5	UNC 3/4	215.9	258	357	121	181	64	106	255	272	113	97
6	UNC 3/4	241.3	284	377	133	189	72	106	255	300	139	123
8	UNC 3/4	298.4	341	436	159	210	73	140	408	360	178	169
10	UNC 7/8	362	412	536	205	264	113	149	408	440	210	207
12	UNC 7/8	431.8	482	586	234	285	113	149	408	510	256	253

Gear

Size (inch)	d (mm)	D3	H3	L1	L2	L3
2	63	160	62	78	112	179
2½	75	160	62	78	112	179
3	90	160	62	78	112	179
4	110	160	62	78	112	179
5	140	160	62	78	112	179
6	160	160	62	78	112	179
8	225	160	62	78	112	179
10	280	200	69	97	130	198
12	315	200	69	97	130	198

